

NO LOCKING
BANDS REQUIRED

Permeter Smooth

Installation Instructions

SCHIEDEL

Contents

Approvals.....	2
Design guide.....	3
Prior to installation.....	4
Connecting flue pipe.....	5
BS EN 15287-1.....	7
System chimney.....	9
Installation instructions.....	12
Offset dimensions.....	15
Firestop components.....	16
Support components.....	17
System design.....	22
Typical external installations.....	23
Load bearing data.....	24
Component weights.....	24
Frequently asked questions.....	25
After installation.....	26
Product guarantee.....	27

Approvals

SYSTEM CHIMNEY

PERMETER SMOOTH is CE certified to EN 1856-1:2009 with designations:

T450 N1 D V2 L99050 G60

System chimney

NOTES



Design guide

MANDATORY REQUIREMENTS

Connection to an appliance which is not connected to the fuel supply, should be carried out by a competent person. We recommend the use of HETAS approved installers for wood burning applications. If installation is carried out by a non HETAS registered installer, the installation must be certified by a local Building Control inspector.

The design guide must be read in conjunction with the detailed component installation instructions. For full design and installation details the key referral documents are:

- BS EN 1856-1: Chimneys - System Chimney Products
- BS EN 1856-2: Connecting Flue Pipes
- BS EN 1859: Metal Chimneys - Testing Methods
- BS EN 1443: Chimneys - General Requirements
- BS EN 15287-1: Chimneys. Design, installation and commissioning of chimneys. Chimneys for non-room sealed heating appliances.
- Approved Document B (Fire safety): Dwellings (England)
- Approved Document J: - Combustion appliances and fuel storage systems (England & Wales)
- BS 476 Part 20: Fire tests on building materials and structures.
- DFP Technical Booklet L: - Combustion appliances and fuel storage systems (NI)
- Technical Handbook (Domestic & Non Domestic), Section 3 - Environment (Scotland)
- Appliance Installation Instructions and related standards. Other standards covering specific applications will also be relevant and must be adhered to.

Planning permission may be required, and reference should be made to the local Building Control Department.

Ensure all chimney components are available and check them to ensure there has been no damage. Do not use damaged components. Build the chimney up through the previous designed route which should be as straight as possible.

Please note that an updated version of this brochure is always available online
<https://www.schiedel.com/uk/brochures>

Prior to installation

VENTILATION

It is very important that sufficient air for combustion and ventilation is provided to the room containing the appliance, to enable correct and efficient working of the appliance and chimney system. Reference should be made to the appliance manufacturer's instructions and recommendations are also given in the Building Regulations Document J, CIBSE guidance notes and BS 5440.

CARBON MONOXIDE ALARMS

The carbon monoxide alarms should comply with BS EN 50291

Where a new or replacement fixed wood burning appliance is installed in a dwelling, a carbon monoxide alarm must be provided in the room where the appliance is located.

Please follow manufacturers instructions with regards to siting and fixing or alternatively :-

- a) On the ceiling at least 300mm from any wall or if it is located on a wall, as high up as possible (above any doors and windows), but not within 150mm of the ceiling and
- b) between 1m and 3m horizontally from the appliance.

N.B Provision of a carbon monoxide alarm should not be regarded as a substitute for correct installation and regular servicing.

HANDLING

It is advised that suitable PPE should be used when handling the products.

DELIVERY TO SITE AND STORAGE

Components should be carefully transported and off loaded. They should be inspected to ensure they have not been damaged, and should be stored off the ground and under cover so that they are protected from accidental damage and the adverse effects of weather.

Connecting flue pipe

APPLIANCE/CHIMNEY CONNECTION

Connection to the appliance can be made using Prima Smooth or alternative approved single wall connecting flue pipes.

The connection must be made by using the appropriate appliance connector. When a single wall connecting flue pipe is used to connect an appliance to the chimney, the lower end of the insulated chimney section must extend a minimum of 425mm below the ceiling. When connecting the appliance to the flue pipe all joints between the flue pipe/appliance outlet must be securely caulked and sealed with non asbestos rope (or suitable alternative) and fire cement on wood burning appliances.

Any flue pipe connection to the chimney **MUST** be made in the same room as the appliance.

CONNECTION TO DRAUGHT DIVERTER

Where the appliance features a draught diverter the connection should rise vertically from it for at least 600mm before any change of direction (unless otherwise specified by the appliance manufacturer). This is in accordance with the recommendations contained in BS 5440 Part 1 section 6.1.4

CONNECTING FLUE PIPE DIAMETER

Connecting Flue Pipe Diameter size should be as recommended by the appliance manufacturer. Under all circumstances the operational requirements of the appliance and the configuration of the flue must satisfy the flue sizing requirements of EN13384-1.

DISTANCE TO COMBUSTIBLES

In accordance with building regulations its is essential that the correct distance to combustible material is maintained. On wood burning applications, where there is a risk of soot fire, a distance of 60mm to combustibles must be maintained when passing through a combustible floor or enclosed within a shaft.

Connecting flue pipe

CONNECTING FLUE PIPE ROUTE

Single wall connecting flue pipes should only be used to connect appliances to Perimeter Smooth. They should not pass through any roof space, partition, internal wall or floor.

Within the room where the appliance is situated, connecting flue pipes should be located so as to avoid igniting combustible material.

On wood burning appliances the maximum length of a connecting flue pipe is 2m. This distance is reduced to 1.5m if any of the acceptable alternative methods of connection are adopted as per BS EN15287-1. (See p.7-8 for full details.)

On appliances with a top outlet, it is recommended that a vertical run of at least 600mm should be allowed immediately above the appliance prior to any change of direction.

On appliances with a rear outlet, it is recommended that there is maximum of 150mm in the horizontal run however under certain conditions, as described in alternative methods in BS EN 15287-1, this may be increased to 450mm. (See p.7-8 for full details.)

Within a system (Connecting Flue Pipe + System Chimney) servicing a wood burning appliance, there should be no more than 4 changes of direction of maximum 45°. 90° Factory made bends or tees within the system may be treated as being equal to two 45° bends (as per Document J of the Building Regulations issued October 2010).

INSPECTION

On wood burning applications, to conform to Building Regulations, provisions should be made to enable a chimney to be inspected and cleaned.

An inspection pipe, inspection elbow or a 90° or 135° Tee with tee cap can form a suitable inspection point (unless cleaning/inspection can be done through the appliance). To aid cleaning, sufficient distance should be left between changes of direction to permit the safe passage of cleaning brushes within the system. This is particularly important on wood burning applications. It is recommended that chimneys serving wood burning appliances be swept as frequently as necessary, but at least twice a year.

BS EN 15287-1

Acceptable alternative methods of connection

Where a horizontal connecting flue of more than 150mm is required to connect a wood burning fired appliance to a chimney, an installation method as per the examples below may be used, provided the following criteria is met:-

- a. The maximum length of horizontal connecting flue pipe does not exceed 450mm;
- b. A Defra exempt appliance or an appliance, which is limited to burning authorised smokeless fuel only, is installed;
- c. A calculation according to BS EN13384-1 has indicated safe operation of the proposed configuration, and the results of the calculation are left with the householder along with the appliance installation instructions;
- d. The appliance manufacturer agrees in writing to the proposed configuration;
- e. The chimney manufacturer agrees in writing to the proposed configuration;
- f. The total length of single wall connecting flue pipe is not more than 1.5m;
- g. The appropriate distances to combustible materials from both the appliance and the connecting flue pipe are maintained.

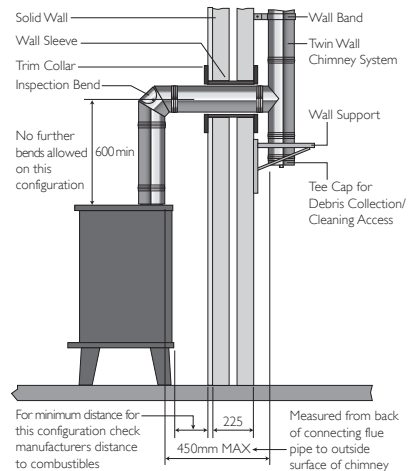
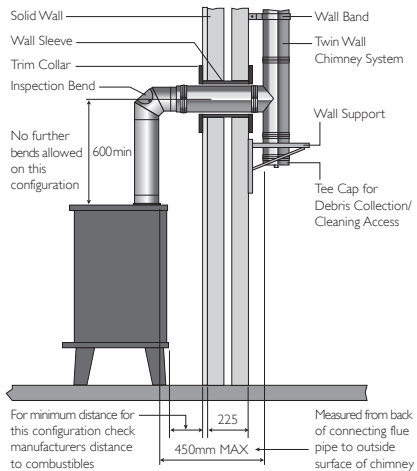

Top outlet single wall connecting flue pipe through solid wall into twin wall system chimney

Nb where the connecting flue pipe from the appliance passes through any wall other than the existing chimney wall, the connecting flue pipe must be a system chimney of twin wall insulated design.

Top outlet twin wall connecting flue pipe through solid wall into twin wall system chimney

BS EN 15287-1

Acceptable alternative methods of connection

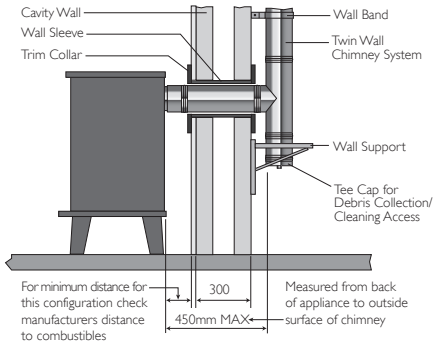

Rear outlet twin wall connecting flue pipe through cavity wall into twin wall system chimney

*Please note these diagrams do not depict Perimeter Smooth, and are only intended to provide general information relating to BS EN 15287-1

System chimney

CHIMNEY DIAMETER

The chimney size should be as recommended by the appliance manufacturer. Where there is a requirement for a flue diameter smaller than the appliance spigot, then the operational requirements of the appliance and the configuration of the flue must satisfy the flue sizing requirements of EN13384-1 for single appliances, and EN13384-2 for multi appliances.

CHIMNEY ROUTE

The chimney should remain as straight as possible through its vertical run to assist flow. Should it be necessary to offset a chimney run then the following guidelines should be adhered to:

It is recommended that a vertical run of at least 600mm should be allowed immediately above the appliance prior to any change of direction. On natural draught systems on any fuel, it is recommended that there should be no more than 4 changes of direction of maximum 45°. Factory made 90° bends or tees within the system may be treated as being equal to two 45° bends (On fan flued appliances, a calculation should be carried out according to BS EN 13384 to ensure that any installation requiring more than 4 changes of direction will satisfy the flue sizing requirements).

DIRECT CONNECTION APPLIANCE TO SYSTEM CHIMNEY

When connecting from the appliance directly to a system chimney, the appropriate appliance connector must be used and the joint between the appliance spigot and the appliance connector must be securely caulked and sealed with non asbestos rope (or suitable alternative) and fire cement.

Where painted product is used on a high temperature application, then this must be a high temperature paint specification. See latest Schiedel Perimeter Smooth catalogue for details of Schiedel High Temperature Paint spec.

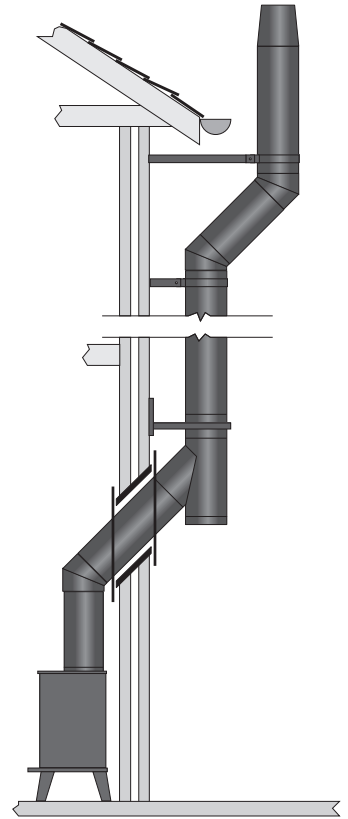

System chimney

DISTANCE TO COMBUSTIBLES

In accordance with building regulations, it is essential that the correct distance to combustible material is maintained. On wood burning applications, using the G60 ventilated Firestop Plates (round or square) in combination with the G60 Ventilated Support Plate is required. Where there is a risk of soot fire, these distances must be maintained, as shown in Fig.1 below.

On bungalow applications where the chimney runs through either a combustible or non-combustible ceiling, an unventilated bungalow fire stop plate kit can be used. Please note that an unventilated support plate can not be used above the ceiling in this case. The weight of the chimney should be supported using the roof support (see p.11). Distance to combustibles must be respected within the ceiling space (see Page 11 Fig.2) and mesh frame should be used within the loft space, which must be ventilated (see Page 11 Fig.2). Please note that trim collars are not to be used as an alternative to firestop plates. They are designed for use as decorative components only.

SUPPORT COMPONENTS

The weight of a chimney system is considerable and requires independent support. Minimal weight should be borne by the appliance. The weight of the chimney can be supported from floor level, or from the wall by using retrofit wall supports or wall support top plates together with side plates or cantilever brackets; or from first floor level by using a support plate and clamp fixed to the floor/ceiling joists.

Wall brackets are non load bearing and provide lateral support only. Refer to the load bearing tables on p.24 for full details of maximum loadings.

Where the flue is free-standing above the roof, a height of 2m can be achieved unsupported using the Cover Bands at the joint immediately below the last support and then every subsequent joint up to 2m.

To go beyond this 2m height, Guy Wire Brackets can be used at 1.5m intervals.

CHIMNEY TERMINATION

For full information relating to chimney termination, please refer to Annex M of BS EN 15287-1. As a guide please refer to page p.22 of these installation instructions.

TERMINALS

Where a terminal with mesh is used, there is a risk of soot build up, and therefore regular cleaning is required to avoid blockage.

System chimney

ENCLOSURE/SHAFTS

With the exception of the room containing the appliance, a mesh frame or alternative, which meets local Building Regulations, should be used where the chimney passes through any part of the building, where there is a risk of accidental human contact, i.e. a bedroom etc., or where there is a risk of contact with combustible materials stored in a cupboard or in the roof-space, the chimney must be enclosed in an appropriate way to meet Building Regulations. In all cases, the minimum distance to any combustible material, including loft insulation, must be respected and any enclosure should be ventilated using the appropriate ventilated fire stops.

Fig. 1

Internal house combustible floors

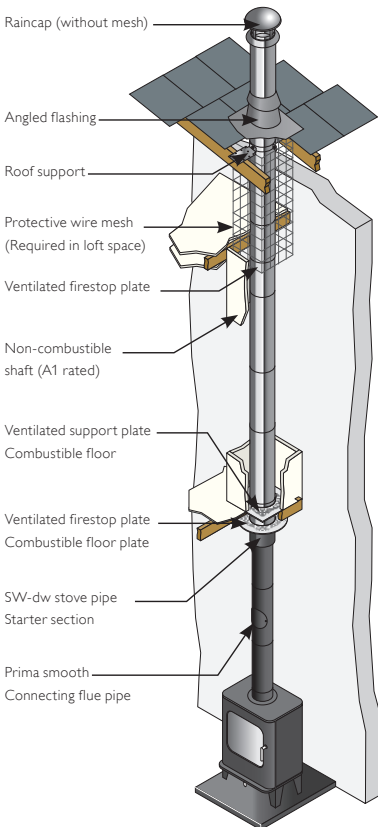
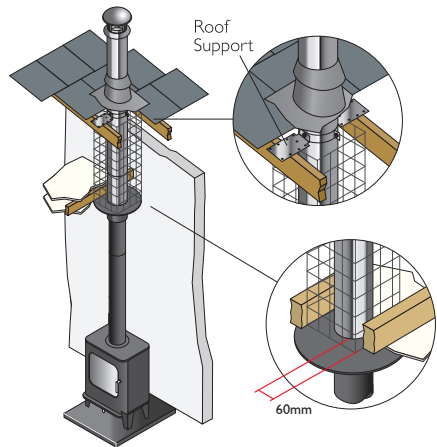

Fig. 2

Internal bungalow (ventilated loft space) combustible and non-combustible floors



Installation instructions

JOINTING SYSTEM

All joints in the Permeter Smooth range are made via a simple push-fit method. This is achieved by pushing together the male and female ends of the two parts. The male end should be pointing in an upward direction (towards termination). Failure to do this could result in condensates gathering in the joint itself, and saturating the insulation.

Locking bands are not required in most situations when fitting Permeter Smooth, but there are Cover Bands available when extra peace of mind is desired. These bands simply wrap around the outside of the joint, and are tightened via two bolts located at the top and bottom of the band.

Note:-joints must NOT occur within floor or ceiling spaces.

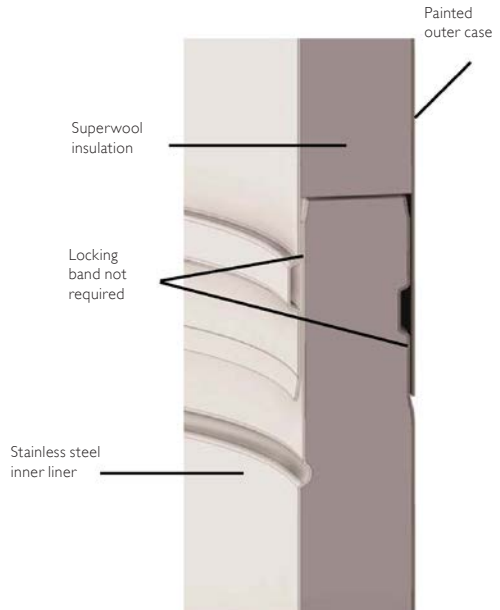

COVER BANDS

Cover Bands (available as standard in the range) are required when offsetting the flue system, and when free standing above the roof:

The final joint before, joints within and the first joint after any offset will require a Cover Band. A freestanding height above the last support of 2m can be achieved, provided a Cover Band is fitted to the final joint BEFORE the final support, and all subsequent joints.

SW-PERMETER SMOOTH ADAPTOR

1. The protruding liner of these components should be pushed into the preceding single-wall pipe with the male end pointing upwards. The liner can be trimmed to suit the depth as required of the appliance spigot.
2. On wood burning appliances the appliance connector should be sealed to the appliance with fire rope and fire cement or high temperature sealant to provide a gas tight joint.

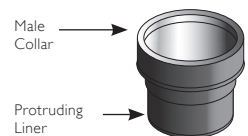

Installation instructions

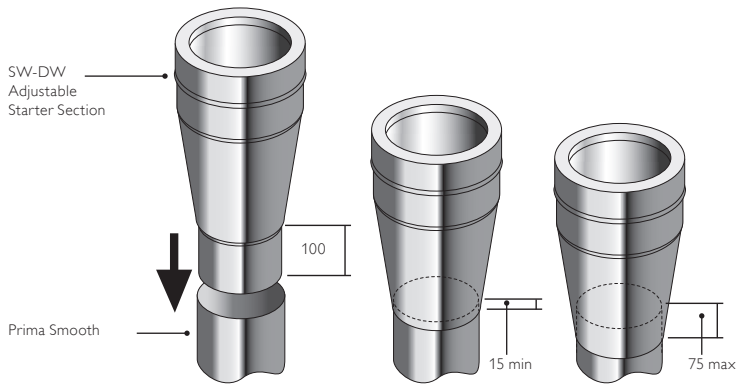

SW-DW ADJUSTABLE STARTER SECTION

The protruding male spigot of the adaptor slides down inside the female socket of the Prima Smooth pipe and the socket of the Prima Smooth pipe slides within the conical section of the starter adaptor, to a maximum length of 75mm into the cone with a minimum of 15mm to ensure a secure connection.

This maximum length of 75mm will leave sufficient space within the adaptor to allow for thermal expansion of the single wall pipe and also to allow for the connecting flue pipe to be removed without cutting, if the appliance has to be moved for servicing.

ADJUSTABLE PIPE/TELESCOPIC PIPES

These are used with standard components to achieve an exact length on site and avoid on-site cutting of components.

1. Calculate the length required.
2. Remove insulation as required to achieve the correct length.
3. Fix the adjusted section to standard components using the locking band provided.



Telescopic pipe

INSPECTION PIPE WITH TEST POINT

The inspection length is a component providing the facility for flue inspection and cleaning, including a test point. It is installed as per a standard pipe section. The removable inspection door must be parallel with the front of the stove, or at least $3 \times$ the internal diameter from any combustible material.



Inspection length

ELBOWS

In cases of top mounted stoves, a minimum vertical height of 600mm from the appliance is recommended prior to any change of direction in the flue pipe.

Installation instructions

90° TEE

This component may be used to connect from a connecting flue pipe to the vertical system chimney at 90° or the branch may be used to locate a draft stabiliser. It is installed as per a standard pipe section.

Tee plugs are not supplied with the tee piece, and must be ordered separately.

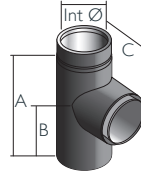

135° TEE

This component may be used in combination with a 45° elbow to connect from a connecting flue pipe to the vertical system chimney. It is installed as per a standard pipe section and provides the least resistance to the flow of the flue gases.

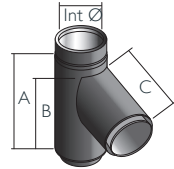

Offset dimensions (made by assembling 2 bends)

30° offset				
Int Ømm	130	150	180	200
Ext Ømm	180	200	230	250
A (mm)	325	325	371	371
B (mm)	87	87	100	100

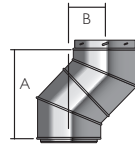

45° offset				
Int Ømm	130	150	180	200
Ext Ømm	180	200	230	250
A (mm)	408	408	399	399
B (mm)	169	169	165	165

30° offset with standard pipe length					
Int Ømm		130	150	180	200
Ext Ømm		180	200	230	250
955mm effective pipe	A (mm)	1152	1152	1198	1198
	B (mm)	565	565	577	577
455mm effective pipe	A (mm)	719	719	765	765
	B (mm)	315	315	327	327
205mm effective pipe	A (mm)	502	502	549	549
	B (mm)	190	190	202	202

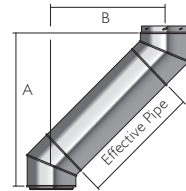

45° offset with standard pipe length					
Int Ømm		130	150	180	200
Ext Ømm		180	200	230	250
955mm effective pipe	A (mm)	1083	1083	1075	1075
	B (mm)	844	844	841	841
455mm effective pipe	A (mm)	730	730	721	721
	B (mm)	491	491	487	487
205mm effective pipe	A (mm)	553	553	544	544
	B (mm)	314	314	310	310

Firestop components

VENTILATED SUPPORT PLATE (GALVANISED PLATE WITH S/S BAND)

The support plate is used where the chimney passes through a combustible floor, and the weight of the chimney has to be taken at floor level. The support plate must be firmly fixed by using bolts or screws. For load bearing Data refer to tables on page 24.

1. Frame a four sided level square opening within the joists using timber stringers where necessary to allow for the correct distance to combustibles from the outer wall of the chimney and for 6 fixing points. When using a any Ventilated Firestop or Support Plates, the minimum distance to combustibles is indicated by the value following "G". The Perimeter Smooth distance to combustibles is 60mm across all diameters. Lower the chimney section through the opening in the floor, and secure to the next section of pipe.
2. Locate the two halves of the support plates around the chimney section, and secure to the joists using screws or bolts.
3. Remove the self-drilling screws which are fastened to the clamp band. Then fasten clamp band around the chimney section and position on top of the plate. Tighten using the nuts and bolts provided.
4. Using the holes in the clamp band as a guide, fasten the three self-drilling screws to the outer case of the Perimeter Smooth system.

Note: Joints must NOT occur within the floor or ceiling joists.

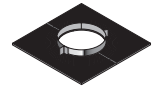

Ventilated support plate

Fig. 1

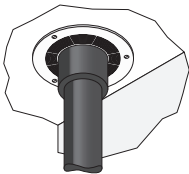

Fig. 2

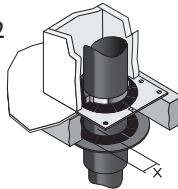
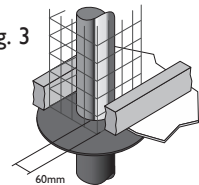
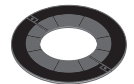

Fig. 3



G60 VENTILATED FIRESTOP PLATE

The ventilated fire stop plates are used in combination with standard Perimeter Smooth pipes where the chimney passes through a combustible floor or ceiling. The outermost circle of ventilation slots gives a distance to combustibles of 60mm. This measures the required distance for wood burning applications which should be measured on site. The fire stop plate should be positioned around the chimney and fastened through the pre-cut plasterboard onto the timber frame with 4.5mm x 60mm long steel screws (see Fig. 2 above) using the location holes provided, ensuring the required safe distances for the application of either gas and oil, or wood burning as above.



Ventilated Firestop Plate

Firestop components

NON-VENTILATED BUNGALOW FIRESTOP

Installed as per a ventilated firestop using the fixing holes provided (see above). Distance to combustibles must be respected - see p.10 for further info.

FIRE STOP PLATE (NON COMBUSTIBLE FLOOR)

This fire stop plate is used exclusively where the chimney passes through a non combustible floor. The two halves of the plate are located around the chimney section and fastened to the floor using bolts or screws provided by others.

Support components

RETROFIT WALL BAND

1. Slide bracket over and down the chimney to the required position.
2. Once the position of the support has been determined, secure the back bracket to the wall with a method of fixing to ensure adequate attachment and support.
3. The wall bracket provides lateral stability only, it is NOT load bearing and is to be positioned at 3 metre centres.

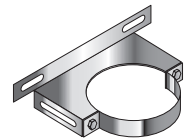

Retrofit wall band

RETROFIT WALL BAND EXTENSIONS

Type W1 gives adjustment of between 55-100mm from the wall.

Once the position of the support has been determined, secure the back bracket to the wall with a method of fixing to ensure adequate attachment and support.

Fasten the structural wall band to the extension brackets using the nuts and bolts provided.



Wall band extensions

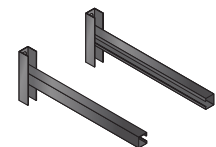

L1 / L2 type

Support components

LOAD BEARING SUPPORTS

All wall supports and floor supports are designed to provide load bearing support for the chimney. They must be used in combination with the relevant lateral support components, wall bands, guy wire brackets or telescopic roof stays as appropriate. See p.24 for further information.

RETROFIT WALL SUPPORT

- Lower the clamp band over the pipe length with the joint facing the wall.
- On the joint, ensure that the spring washer is between the plain washer and the bolt head,
- Tighten the two fixing bolts on the clamp band using a torque wrench up to a minimum of 10 Nm (Newton-Meters).
- Attach the side brackets to the fixing bolts on the side of the band, but don't tighten.
- Attach the side brackets to the wall using a method of fixing to ensure adequate attachment and support, i.e. shield anchors.
- Mark up the hole positions for the brackets on the wall.
- Fix the brackets to the bolts on the side of the clamp band using the locking nuts provided.
- For maximum height of chimney see load bearing details on p.24.



ADJUSTABLE TOP PLATE

The wall support is designed to be used internally or externally to provide either initial or intermediate support for the vertical chimney. It is used in combination with side plates. The turned down edge at the front of the plates is slotted to allow for the plate to slide along the cantilever brackets and give some positional adjustment. The female socket on the pipe attached to the underside of the plate should be pushed down onto the preceding pipe. The top plate is then attached to the side plates or the cantilever brackets using the bolts provided through the fixing slots in the top plate. The bolts should then be tightened firmly.

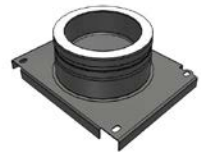

For maximum height of chimney see load bearing details, please refer to tables and diagrams on pages 24.

Top plate				
SAP code	114888	114866	114859	114860
Int Ømm	130	150	180	200
Ext Ømm	180	200	230	250
A (mm)	238	258	278	285
B (mm)	305	325	355	353
C (mm)	155	155	155	155
X (mm)	95	95	95	95

Support components

SIDE PLATES/CANTILEVER BRACKETS

Once the position of the support has been established in relation to the chimney route, secure the side plates or cantilever brackets to the wall using expansion bolts to ensure adequate attachment and support (see Fig. 2).

Side plates (pair)				
SAP code	115369	115774	115977	116178
Int Ømm	130	150	180	200
Ext Ømm	180	200	230	250
A (mm)	310	315	345	365
B (mm)	470	470	470	470

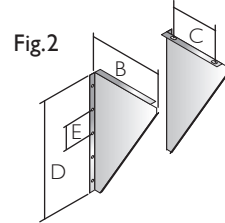

Side plates

ROOF SUPPORT

The roof support is supplied as a kit complete with two side plates for fixing to the roof trusses, a band to give lateral support to the chimney as it passes through the roof, and 3 self tapping screws, which are secured to the chimney through the band to give a load bearing capacity. When the plates are installed above the roof trusses as in Fig.1 the maximum number of pipes, which may be suspended from the roof support is 6 x 1m pipes. When the plates are attached below the trusses as in Fig.2 the maximum number of pipes, which may be suspended is 4 x 1m pipes.

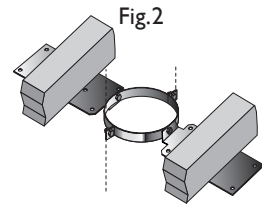
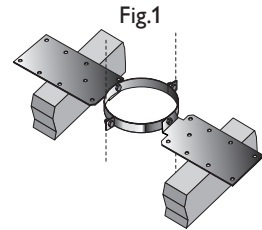

1. The band should be lowered down over the top of the Perimeter Smooth pipe, and positioned so that the side plates are resting on top of the roof trusses as in Fig.1 or below the roof trusses in the case of Fig. 2. The recommended position is always as per Fig.1 where circumstances allow this solution.
2. The band should then be tightened using the nut and bolt provided.
3. Using the holes pre-drilled in the roof support band, drill 3mm holes in the outer case of the chimney section (drill bit should be set for a depth no greater than 10mm to avoid any damage to the liner of the chimney)
4. Use the self tapping screws provided to secure the clamp band to the outer casing of the chimney section.

Please note: It is the responsibility of the installer to ensure that the truss to which the roof support is being attached is load bearing and capable of withstanding the weight of the system being installed.

Support components

GUY WIRE BRACKET

This component should be used to secure unsupported chimney sections above roof level. Guy wires or preferably, telescopic stays or rigid stays (supplied by others) must be fixed to the bracket and secured to suitable anchorage points to ensure that the chimney sections are stable. A maximum chimney height of 2 metres from the last support, or from the roof is permitted. Additional height requirements MUST be supported using guy wire brackets, with suitable guy wires or rigid stays or by using telescopic roof stays.

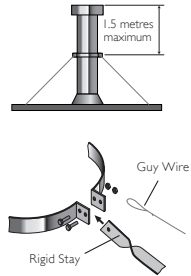

WALL SLEEVE (90° & 135° VARIANTS)

Wall sleeves must be used to protect the building where the chimney passes through a wall (see Fig. 2 & 3). The 90° version is supplied as a straight length whereas the 135° version is mitred at 45 degrees on one end. The sleeve should be cut down to the correct length on site to fit flush with the wall (see Fig. 1 & 2). The sleeve should be adequately weatherproofed, using a good quality building mastic and rope fibre.

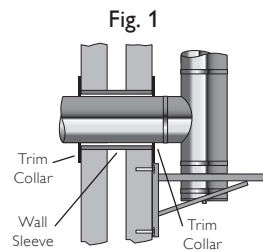

TWO PIECE TRIM COLLAR (90° & 135° VARIANTS)

Two piece trim collars are fitted around the Perimeter Smooth pipe where it protrudes through both the inside and the outside of the wall (see Fig. 1 & 2). They should be fastened to the wall using an adequate method of fixing. The trim collars should be adequately weatherproofed back to the wall and around the chimney, using a good quality building mastic or equivalent.

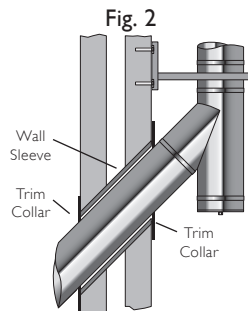

COVER BANDS

Cover Bands are used to provide extra support to each joint (where required). They consist of a smooth band and two micro-toggles. The lead-in edge of the band must be facing towards termination, to help mitigate water ingress.

When offsetting, a cover band must be used on the final joint before the offset, any joint within the offset and the first joint after the offset.

An unsupported height of 2m can be achieved provided Cover Bands are used on the joint directly before the final support, and all subsequent joints.

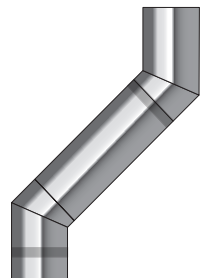

Support components

ANGLED FLASHING

Manufactured in sheet aluminium for use on pitched roofs. The base of the flashing should be nailed or screw fixed to the roof batons prior to tiling. The front edge of the flashing should be hooked to the underside of the batons to prevent lifting. This component should be sealed with the mastic sealant provided and **MUST** be used in conjunction with the storm collar supplied.

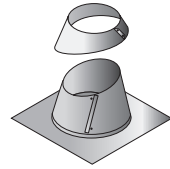

Angled flashing

System design

TERMINALS

Terminals are supplied complete with a locking band. Once the terminal has been pushed into place, the adjustment bolt on the locking band clip should be tightened to ensure that the terminal is properly secured to the previous pipe.

Raincap
with mesh



Anti splash
terminal
without
mesh



OUTLET SITING

Flue terminations for wood burning appliances are subject to EN15287-1 2007. Figures A and B illustrate recommendations for the most commonly encountered outlet terminations. Flue terminations. Figure C illustrates recommendations for the most common siting situations encountered. Adjacent taller structures may require increased height. The minimum flue projection through the roof is 600mm to the underside of the terminal.

OUTLET SITING FOR WOOD BURNING APPLIANCES (<50KW)

Point where flue passes through weather surface (Notes 1, 2)	Clearance to flue outlet
A At or within 600mm of the ridge	At or within 600mm above the ridge
B Elsewhere on the roof (whether pitched or flat)	At least 2300mm horizontally from the nearest point on the weather surface and: a) at least 1000mm above the highest point of intersection of the chimney and the weather surface; or b) at least as high as the ridge
C Below (on a pitched roof) or within 2300mm horizontally to an openable roof-light, dormer window or other opening (Note 3)	At least 1000mm above the top of the opening
D Within 2300mm of an adjoining or adjacent building, whether or not beyond the boundary (Note 3)	At least 600mm above any part of the adjacent building within 2300mm

LOCATION OF OUTLET

Fig. B
Outlet siting for wood burning
appliances (<50kw)

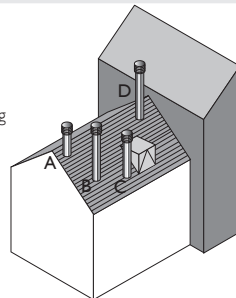

1. The weather surface is the building external surface, such as its roof, tiles or external walls.
2. A flat roof has a pitch less than 10°.
3. The clearance for A or B, as appropriate, will also apply.
4. A vertical flue fixed to an outside wall should be treated as equivalent to an inside flue emerging at the nearest edge of the roof.

Typical external installations

Wall mounted installation with pair of cantilever brackets and structural locking bands

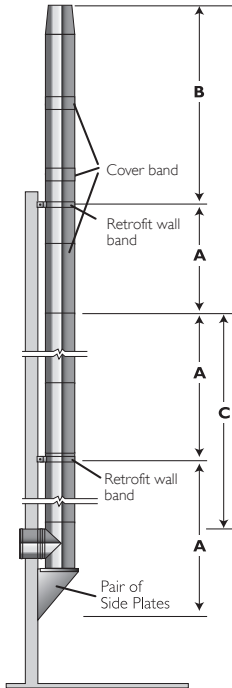

Offset installation (45°) with pair of side plates

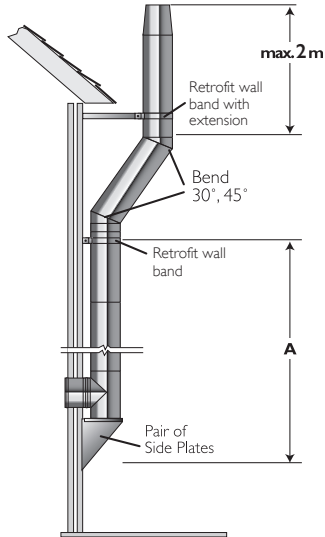

Max Offset Info
(in same plane)

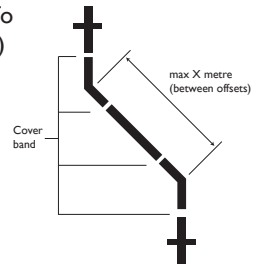

Distance between lateral supports				
Int Ø mm	130	150	180	200
A (m)	3	3	3	3
B (m)	2	2	2	2
C (m)	15	15	15	15
D (m)	10	10	7	7

Int Ø	130-200
X (m)	3

Load bearing data

Maximum load bearing (metres of pipe)				
Internal Diameter (mm)	130	150	180	200
Retrofit Wall Support	10	10	7	7
Top Plate + Side Plates (A)	15	15	15	15
Top Plate + Side Plates (B)	10	10	10	10
Ventilated Support Plate	12	12	12	9
Retrofit Wall Band	3	3	3	3
Guy Wire Bracket	1.5	1.5	1.5	1.5
Roof Support (above truss)	6	6	6	6
Roof Support (below truss)	4	4	4	4
Extension for Retrofit Wall Band	3	3	3	3

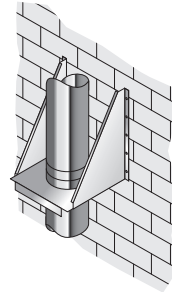

Diagram A

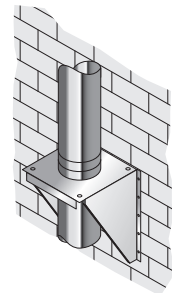

Diagram B

Component weights

Approximate weights of products (kg)			
Int Ømm	Length		
	1000mm	500mm	250mm
130	5.84	2.89	1.42
150	6.58	3.26	1.59
180	7.69	3.8	1.86
200	8.43	4.17	2.04

Frequently asked questions

WHAT IS THE MAIN ADVANTAGE OF PERMETER SMOOTH?

The most obvious benefit to Permeter Smooth is the lack of Locking Bands - The system relies on a friction inter-fit between two parts, which provides structure and removes the need for Locking Bands in the majority of the system.

WHERE WOULD YOU USE COVER BANDS?

Cover Bands are used to provide extra strength to a joint, and are 150mm in height. They are used in two main scenarios:

- When offsetting the flue system, or;
- When a freestanding height of 2m is required above the last support.

ARE THERE OTHER FINISHES AVAILABLE?

We are only launching the black product initially. No plans are currently in place to introduce any additional painted variants, or an unpainted version

WHAT IS THE WARRANTY/GUARANTEE PERIOD?

The warranty period for Permeter Smooth will be 10 years, with the usual caveats to this guarantee; Installed to our instructions, swept regularly, carried out by a HETAS registered installer/competent person etc.

After installation

TESTING AND COMMISSIONING PRIOR TO FIRST USE

A flue flow test (Smoke Test) must be performed as outlined in BS EN 15287-1. In addition to this, a draught measurement must also be taken and recorded to verify that the installed system fulfils the draft requirements specified by the appliance manufacturer for the specific appliance.

APPLIANCE OPERATION

Appliance slumbering must be avoided, and if the appliance has been run on low fire conditions for an extended period, then it is advisable to run the appliance at controlled high fire condition for a minimum period of at least 30 minutes afterwards. Prolonged slumbering of the appliance at all times is a contributing factor to a system chimney failure. It is important to maintain sufficiently high flue gas temperatures in order to avoid condensate and acid corrosion problems, and to ensure complete combustion of the fuel at all times. If corrosion occurs due to slumbering, then the guarantee will be invalidated on the system.

MAINTENANCE

Each chimney must be designed to allow for easy inspection; sweeping should be carried out by competent persons. On wood burning applications a list of HETAS registered sweeps can be found at www.hetas.co.uk. Chimney flue cleaning and inspection require the use of appropriate tooling – under no circumstances should chemical cleaners or mild steel tools be used to sweep stainless steel chimneys. Cleaning/inspection of any chimney system should be carried out at least once a year, along with maintenance of the appliance, but it is recommended that chimneys serving wood burning appliances be swept at least twice a year, at the end of the heating season to remove any deposits, which may have built up during the season, and prior to the start of the next heating season to ensure that the flue way is clear of any blockages such as birds nests etc.

We would advise that monthly checks are carried out to ensure that there is no build up of any deposits in the flue way of the connecting flue pipe or system chimney.

PAINTED PRODUCTS

Painted products are relatively maintenance free however should the product require cleaning then please follow the guidelines below:

- Ensure the system has fully cooled down as the paint may have softened due to exposure to high temperatures and this will prevent unintended damage to the paintwork.
- Carefully remove any loose surface deposits with a wet sponge (taking care not to scratch the painted surface).
- Use a soft brush (non abrasive) or a lint free cloth and a diluted solution of a mild detergent, e.g., pH-neutral liquid hand dish-washing detergent in warm water (DO NOT use solvents or aggressive household cleaners) and wipe down.

To remove all remaining residues, finish off with a wipe down using a clean lint free cloth with fresh water.

After installation / product guarantee

FUEL STORAGE AND USAGE

Where wood burnings are being used, correct storage is critical and fuels must be kept dry. Wood must be seasoned prior to use, with a maximum moisture content of 20%. Only approved fuels should be used. Refer to HETAS list for details on www.hetas.co.uk. The fuel used must be suitable for the appliance - please refer to manufacturer's instructions.



NOTICE PLATE FOR PERMETER SMOOTH PRODUCT

The Notice plate should be marked up in indelible ink and securely fixed in an unobtrusive but obvious position within the building such as: Next to the electricity consumer unit. Next to the chimney installation described. Next to the water supply stop-cock.

PRODUCT GUARANTEE

We are confident in our products and so offer you (the owner) a generous guarantee in relation to the Perimeter Smooth system (the System). Provided that you comply with the conditions stated below, the system will be free from defects for 10 years.

The conditions of the guarantee are:

- Correctly sized and installed in accordance with the manufacturer's instructions, current Building Regulations and relevant British and European standards.
- Maintained correctly by a qualified and competent person and maintenance records kept updated for both appliance and chimney/chimney liner.
- Used in combination with an appliance burning only approved fuels in accordance with Schiedel Chimney Systems and the appliance manufacturer's instructions.
- Familiarise yourself with the installation instructions and comply with its provisions in full during the lifetime of your usage of the product (including by keeping the required records safe). Failure to do so will invalidate any guarantee claim.

For more details about the guarantee visit our website. For recommended fuels listings, please refer to the HETAS Guide www.hetas.co.uk

In the event of a fault developing in the product due to defective materials or faulty manufacture Schiedel Chimney Systems undertake to replace the product only. Schiedel Chimney Systems cannot accept liability nor take any responsibility for the installation, building or redecorating costs or any other consequential losses arising. If any complaint is found to be a result of faulty installation, non-compliance with or abuse contrary to these conditions, the cost of site investigation is chargeable.

SCHIEDEL

Schiedel Chimney Systems Ltd.

Crowther Estate

Washington

Tyne & Wear NE38 0AQ

Tel. +44 (0)191 416 1150

sales.uk@schiedel.com | www.schiedel.com/uk

A **standard**
INDUSTRIES COMPANY