

JUPITER 550 - 850

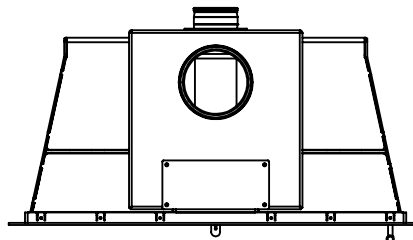

JUPITER 550 - 850, FRISKLIFT BAG.

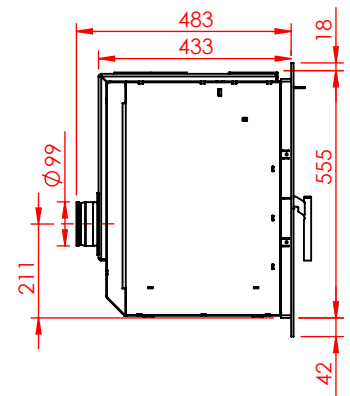
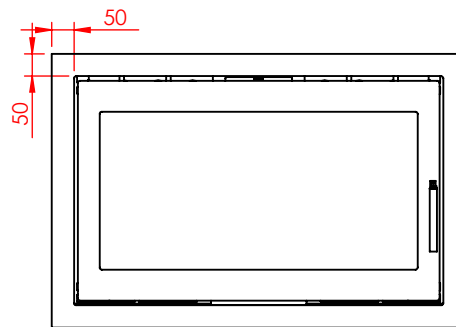
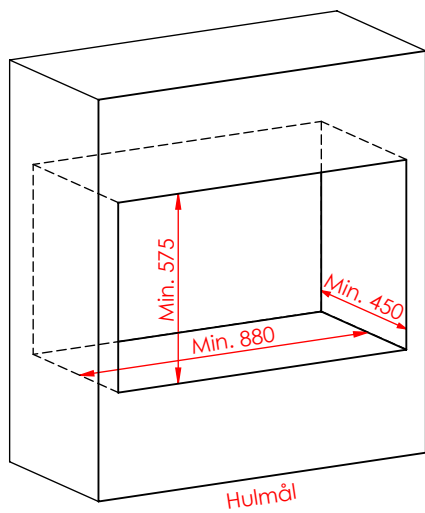
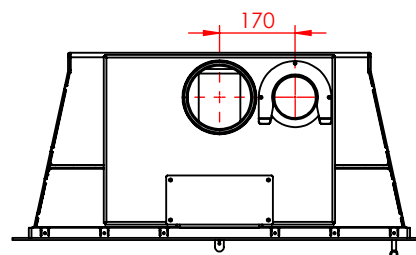
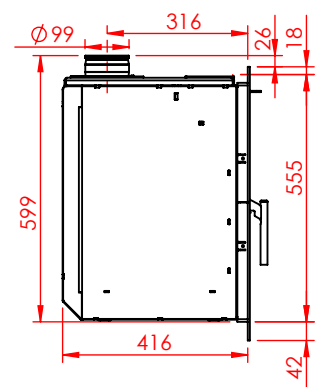
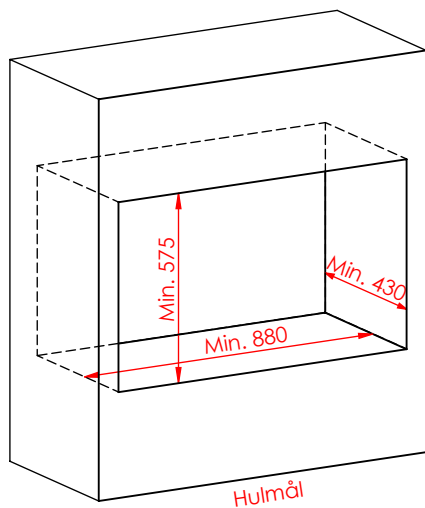

JUPITER 550 - 850, FRISKLIFT TOP.

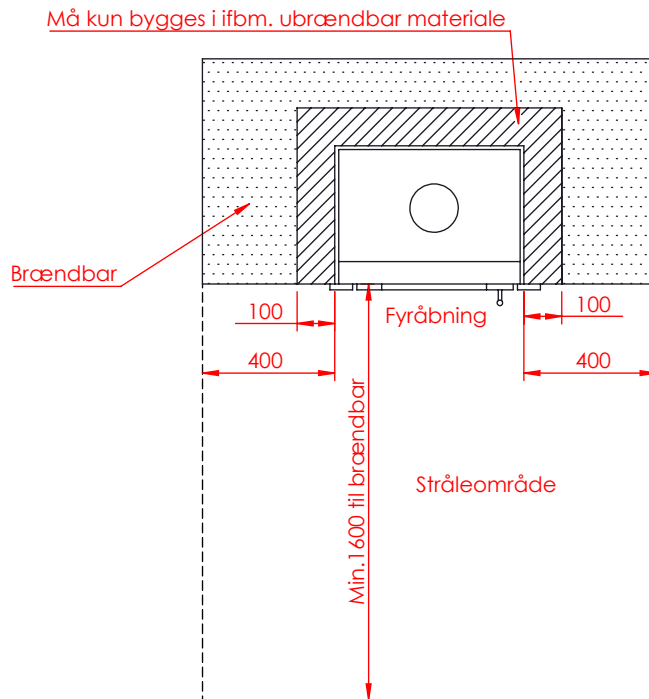

AFSTAND TIL BRÆNDBART.

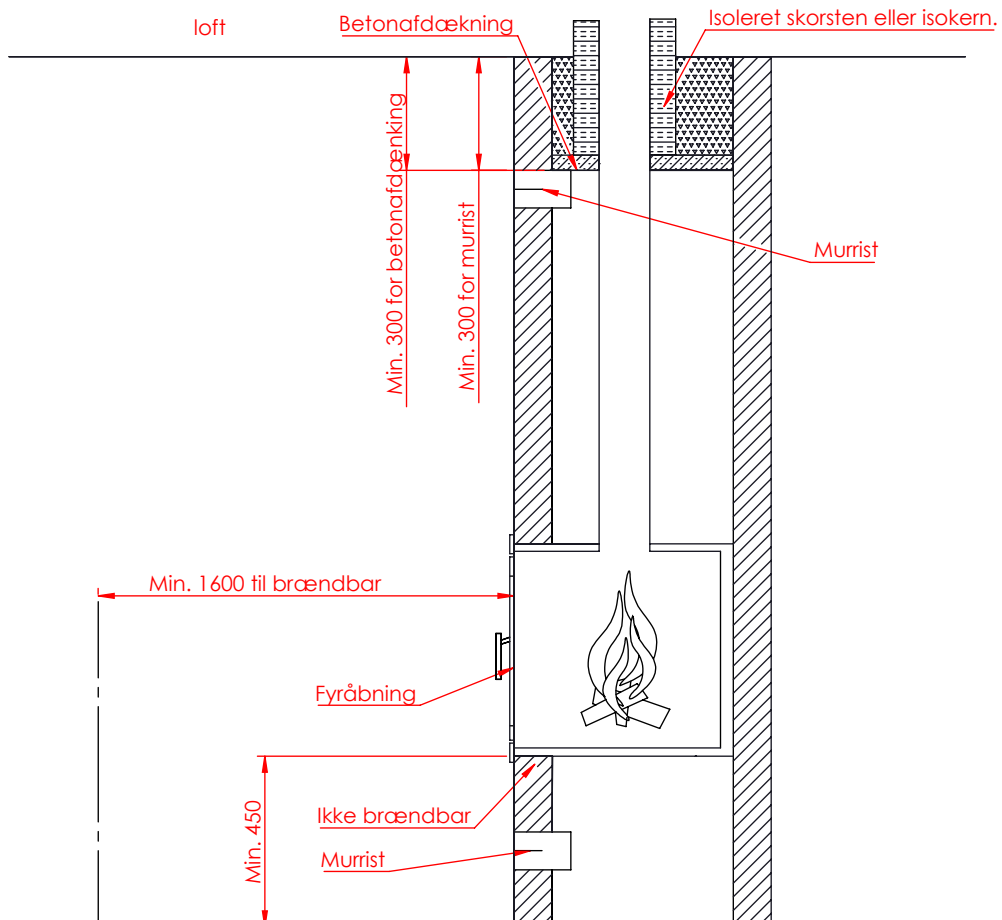

AFSTAND TIL BRÆNDBART.

DATA: JUPITER 550-850

Jupiter 550 - 850	
Glasmål:	728 x 367 mm.
Driftseffekt:	6 - 12 Kw
Nominel ydelse:	9 Kw
Røgstuds:	Ø 150 mm.
Virkningsgrad:	79 %
Ekstraudstyr:	Rysterist.
Ekstraudstyr:	Friskluft.